

Product Appearance



Product Features

- 1. DLC5.1& FCC listed with LM79 & LM80
- 2. High luminous efficacy 160lm/w
- 3. High quality isolated driver, 0-10V dimming, Flicker free
- 4. PF > 0.95, driver efficiency > 88%,THD < 20%
- 5. Installation: hanging,it can add extra motion sensor or emergency battery.
- 6. Suitable for dry/damp location
- 7. Designed for warehouses, gymnasiums, and industrial spaces
- 8. CCT: 4000K & 4500K& 5000K& 5700K
- 9. Five years warranty

Product Dimension

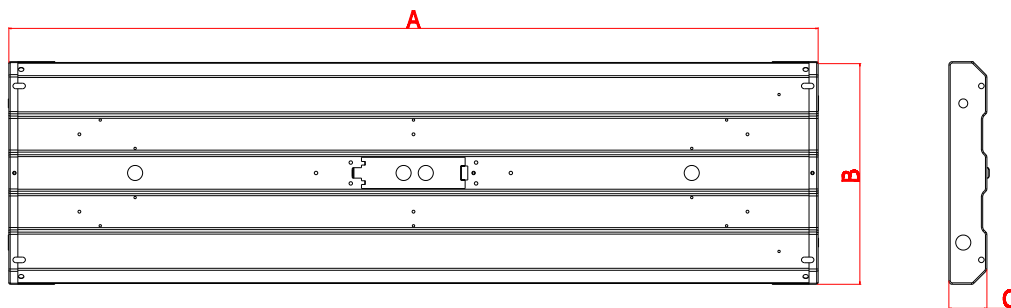

Mode	A (inch)(mm)	B (inch)(mm)	C (inch)(mm)
2FTLHBA-80WLH	23.82"(605mm)	12.60"(320mm)	2.17"(55mm)
2FTLHBA-110WLH	23.82"(605mm)	12.60"(320mm)	2.17"(55mm)
2FTLHBB-165WLH	23.82"(605mm)	17.32"(440mm)	2.17"(55mm)
2FTLHBB-220WLH	23.82"(605mm)	17.32"(440mm)	2.17"(55mm)
4FTLHBA-165WLH	45.79"(1163mm)	12.60"(320mm)	2.17"(55mm)
4FTLHBA-225WLH	45.79"(1163mm)	12.60"(320mm)	2.17"(55mm)
4FTLHBB-325WLH	45.79"(1163mm)	17.32"(440mm)	2.17"(55mm)
2FTLHBA-110WHH	23.82"(605mm)	12.60"(320mm)	2.17"(55mm)
2FTLHBB-165WHH	23.82"(605mm)	17.32"(440mm)	2.17"(55mm)
2FTLHBB-220WHH	23.82"(605mm)	17.32"(440mm)	2.17"(55mm)
4FTLHBA-225WHH	45.79"(1163mm)	12.60"(320mm)	2.17"(55mm)
4FTLHBB-325WHH	45.79"(1163mm)	17.32"(440mm)	2.17"(55mm)

Specification

Part No.	Power	Input Voltage	Size	Input Current	PF	Light Efficacy	Ra	CCT
2FTLHBA-80WLH	80W	AC120-277	2FT	0.8A	>0.95	160lm/w	80	4000-5700K
2FTLHBA-110WLH	110W	AC120-277	2FT	1.1A	>0.95	160lm/w	80	4000-5700K
2FTLHBB-165WLH	165W	AC100-277	2FT	1.65A	>0.95	160lm/w	80	4000-5700K
2FTLHBB-220WLH	220W	AC100-277	2FT	2.2A	>0.95	160lm/w	80	4000-5700K
4FTLHBA-165WLH	165W	AC100-277	2FT	1.65A	>0.95	160lm/w	80	4000-5700K
4FTLHBA-225WLH	225W	AC100-277	4FT	2.25A	>0.95	160lm/w	80	4000-5700K
4FTLHBB-325WLH	325W	AC100-277	4FT	3.25A	>0.95	160lm/w	80	4000-5700K
2FTLHBA-110WHH	110W	AC347-480	2FT	0.33A	>0.95	160lm/w	80	4000-5700K
2FTLHBB-165WHH	165W	AC347-480	2FT	0.5A	>0.95	160lm/w	80	4000-5700K
2FTLHBB-220WHH	220W	AC347-480	2FT	0.67A	>0.95	160lm/w	80	4000-5700K
4FTLHBA-225WHH	225W	AC347-480	4FT	0.68A	>0.95	160lm/w	80	4000-5700K
4FTLHBB-325WHH	325W	AC277-480	4FT	1.25A	>0.95	160lm/w	80	4000-5700K

Testing Report

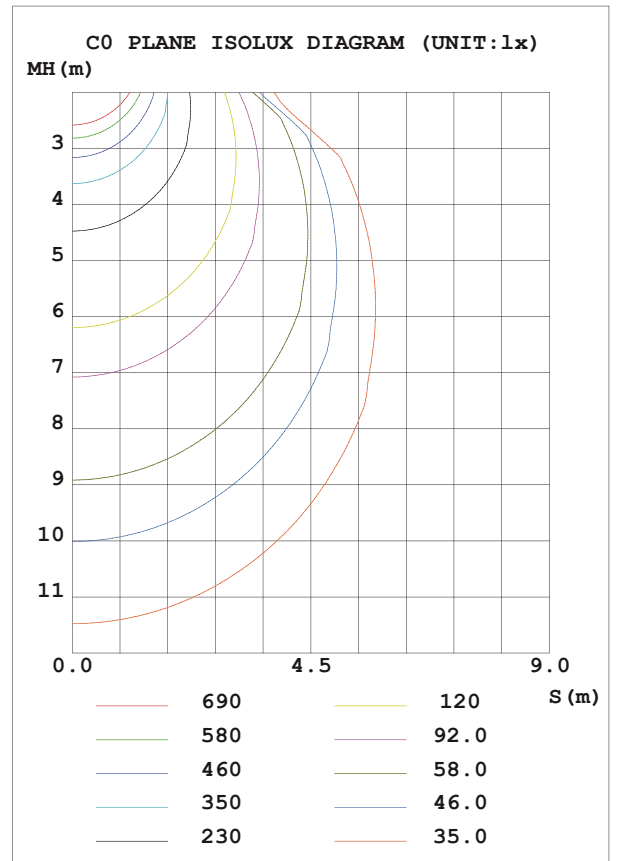
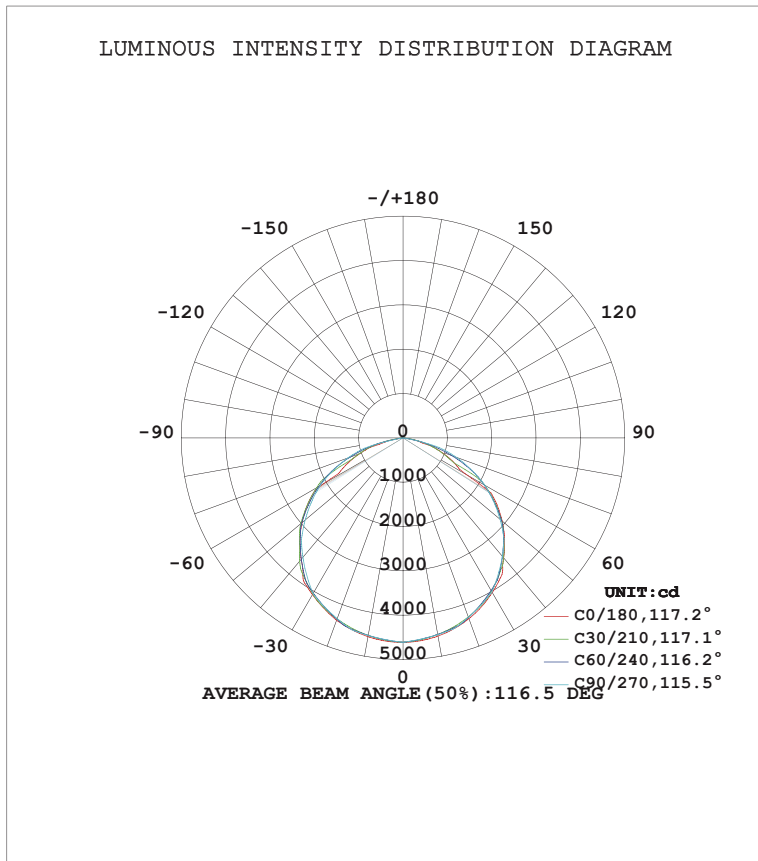

Hanging installation instruction

Please turn off the power before installation

1. Hook the chain as below pic.



2. Insert the hook into the slotted holes, as shown below.

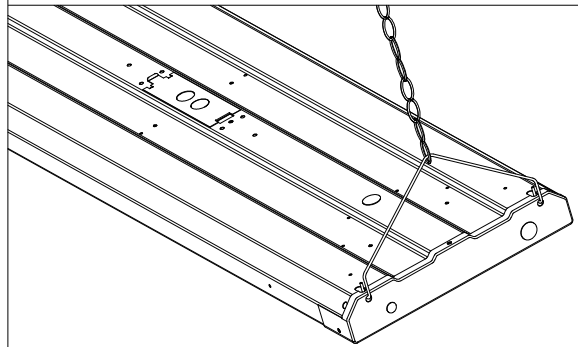

3. Hook up the chain on the ceiling anchor.

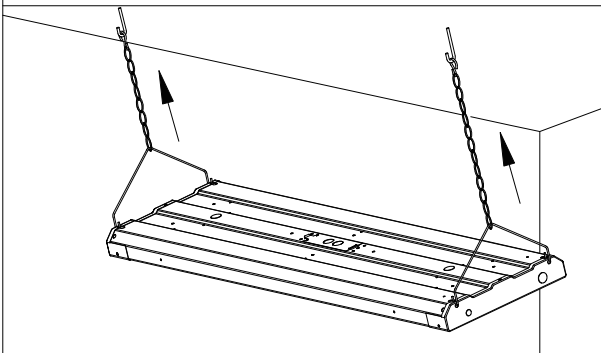

4. Turn off power, and make wiring connections with screw-on wire connectors.

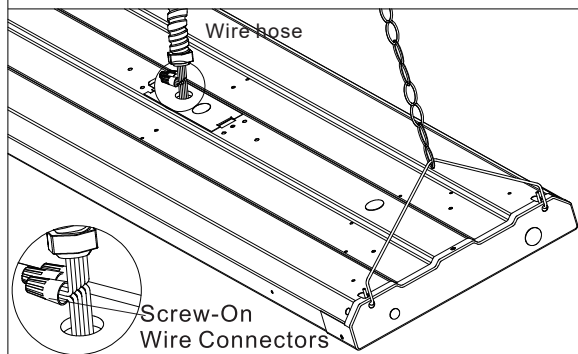

5. Insert the terminal cap and wires into the driver box.

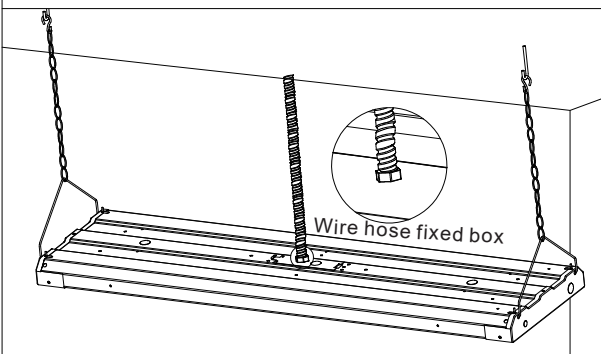

Wiring instruction

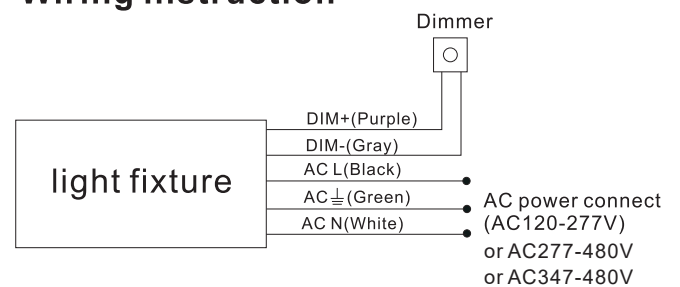

Surface Mounting instruction

Please turn off the power before installation

1. Drill holes in the ceiling according to the the L bracket holes.

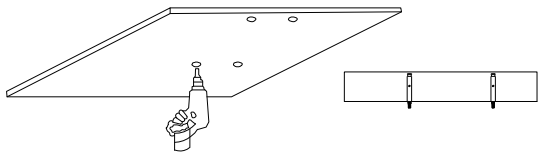

2. Insert the screws into the holes and fix the L brackets with provided accessories.

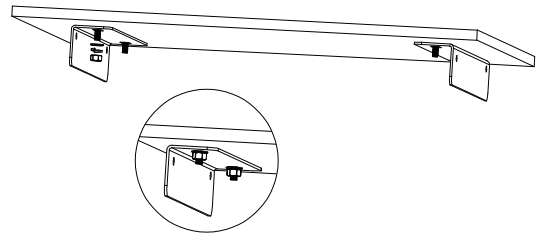

3. Match the holes on each side of the Linear highbay with the L bracket.

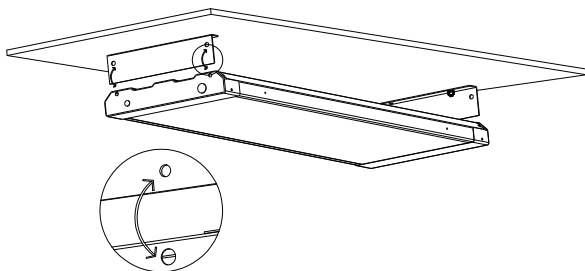

4. Insert screws into the matched holes to fix the Linear Highbay on the L bracket.

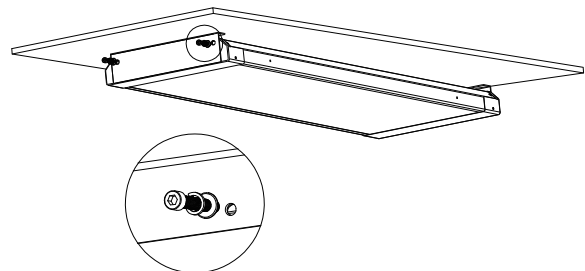

5. Use screws to lock up the linear highbay -together with the L bracket.

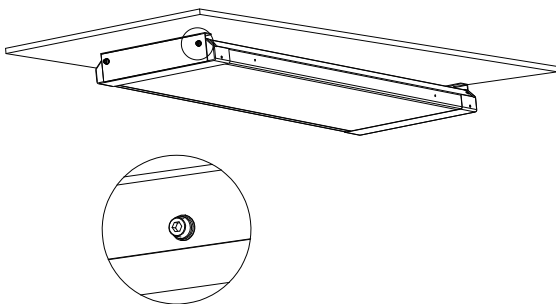

Wiring instruction

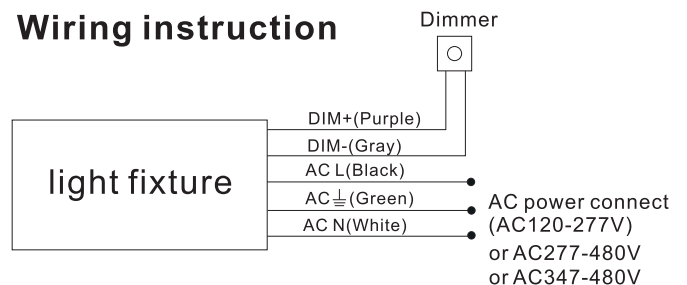

Pipe installation instruction

Please cut off the power before Installation

1. Fix the expansion screws into the right place on the ceiling.

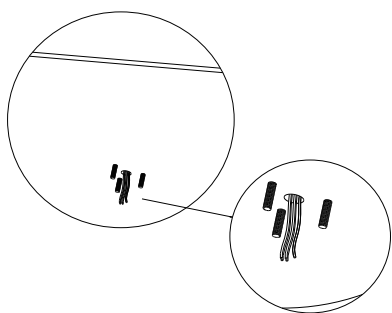

2. Pull wires through the pipe hole and then connect the pipe with u shape brackets by screws.

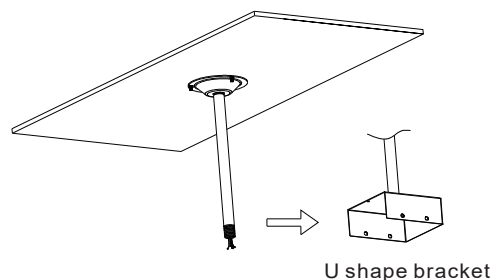

3. Fix the 2pcs L shape bracket with screws 3 holes at the back of the linear highbaty.

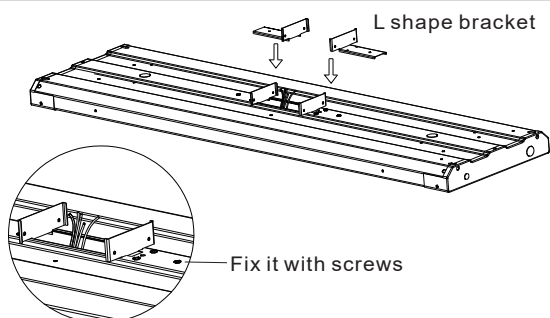

4. Connect u shape brackets with L shape bracket by screws. then make wiring connections with screw-on wire connectors.

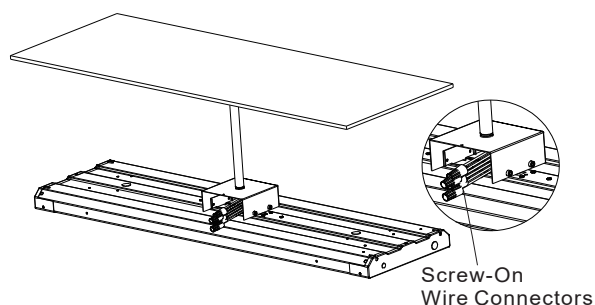

5. Connect the wires, and then Lock the cover with screws.

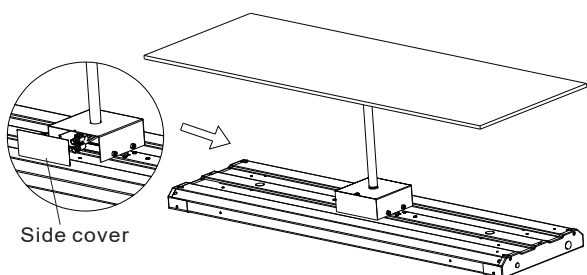

Wiring instruction

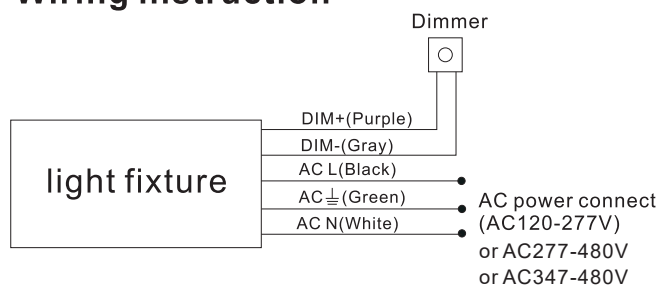

Microwave motion sensor

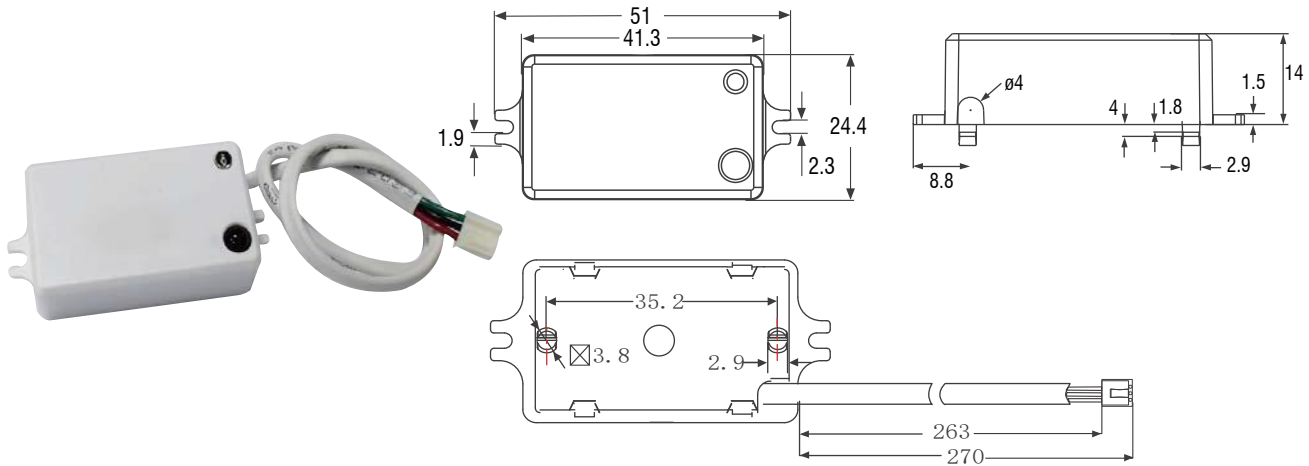

Technical data

Operating voltage	12VDC
Operating current	≤25mA
Output	DIM/0-10V
Stand-by power	≤0.5W
Detection area	25%/50%/75%/100%
Hold time	5s/30s/1min/3min/5min/10min/20min/30min
Daylight threshold	2Lux/10Lux/30Lux/50Lux/80Lux/120Lux/Disable
Stand-by period	0s/10s/30s/1min/5min/10min/30min/+∞
Stand-by dimming level	10%/20%/30%/50%
Microwave frequency	5.8GHz±75MHz
Microwave power	<0.3mW
Mounting height	Max.15m/49.2ft (ceiling mounted)
Detection range	Max.∅14m/45.92ft (ceiling mounted)
Operating temperature	-20°C~+60°C
Motion detection	0.5~1.5m/s
IP rating	IP20
Warranty	5 years

Factory Default Setting: Detection area 100%/ Hold time 5s/ Daylight threshold Disable/Stand-by period 0s/Stand-by dimming level 10%.

Wiring

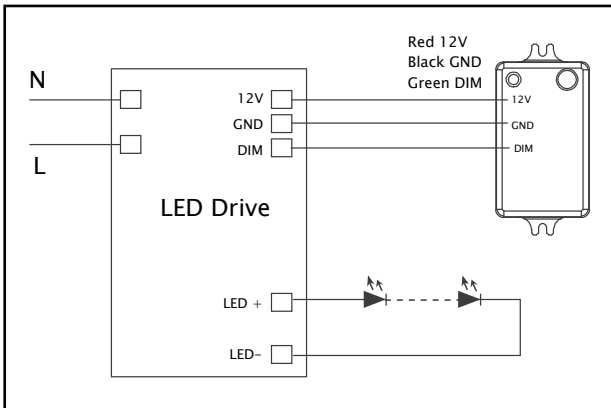

Structure

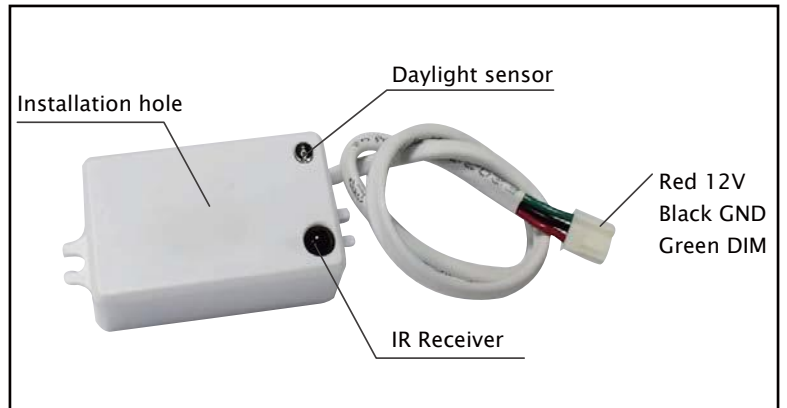

MOUNTED TO LINEAR HIGH BAY LIGHT

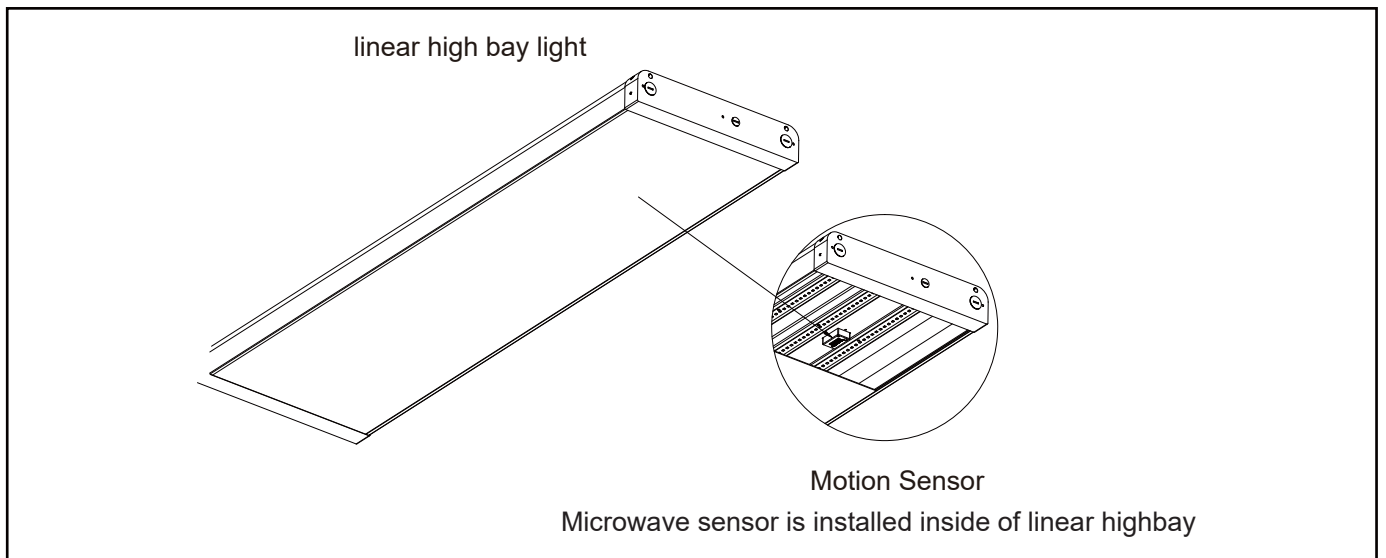

Function

● Detection Patterns

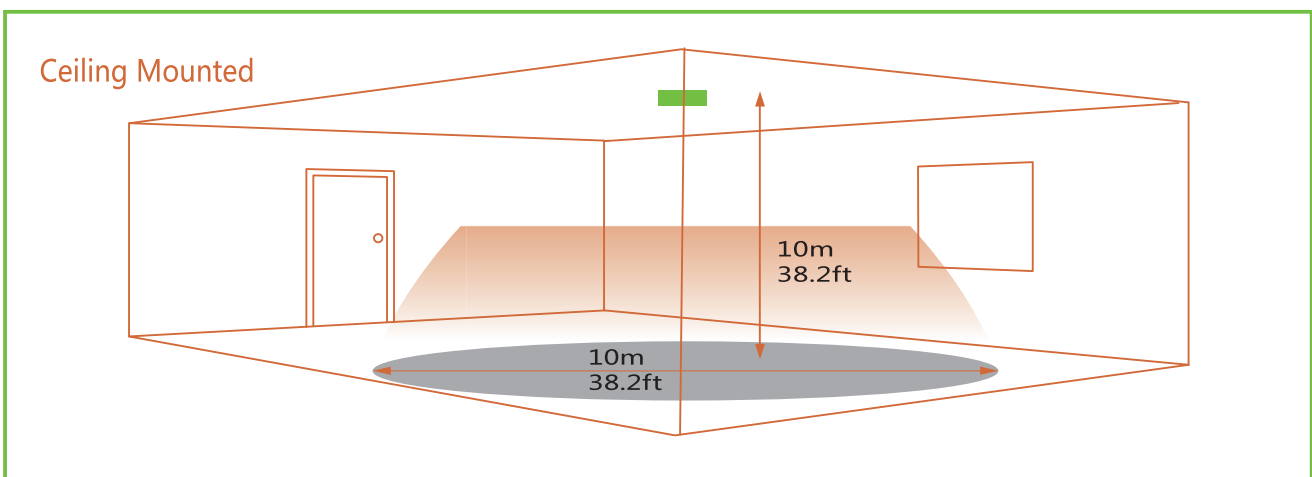

● **Customer can set it according to actual needs with a remote controller.**

ON/OFF Press the "On/off" button, the light keeps permanently on or off. Press "Auto Mode", "Reset" or "Apply" buttons to quit from this mode.

Auto Mode Press "Auto Mode" button, the sensor starts to work and all settings remain the same before the light gets switched on/off.

Reset 1. Press "Reset" button, change brightness to max level.
2. Press "Reset" button, products with DIP switch will be controlled by DIP switches; otherwise all the setting will be just initial, that is 100% detection range, hold time 5s, no stand-by time and daylight threshold disabled.

+/- Flick only after press "Apply" button
1. To adjust brightness 10-100% in on/off mode.
2. To adjust highest brightness 60-100% in sensor mode.

Start Press "Start" to customize scene, users can change detection range, daylight threshold, holdtime, standby dimming level and standby period.

Memory 1. Press "Memory" to save all the settings.
2. The settings remained as the last time if not get resetted values.

Apply 1. Press "Apply" to deliver the saved setting.
2. Press "Apply" without "memory" will make all the setting one-time operation.
3. Settings should be done within 30S, otherwise it exits memory mode.

Detection area Press to define detection area 100%/75%/50%/25%.

Hold time Press to define holdtime 5s/30s/1min/3min /5min/10min/20min/30min.

Stand-by dimming level Press to define stand-by dimming level 10%/20%/30%/50%.

Stand-by period Press to define stand-by period 0s/10s/30s/1min/5min/10min/30min/+∞.)
Note: "0s" means no standby period; "+∞" means unlimited standby period.

Daylight threshold Press to define daylight level 2Lux /10Lux /30Lux/50Lux/80Lux/120Lux/Disable.
Note: Disable means light will be turned on once sensor detects movement, regardless of the ambient lux.

Test (2s) The button "Test (2s)" is for testing purpose after commissioning. Pressing this button, the sensor goes to test mode (hold time is only 2s)

● **Lux on/off**

Adopted dual PD technology, it is able to differentiate artificial light brightness from natural light after installed inside the fixture, and automatically turn off light when ambient brightness exceeds preset lux level.

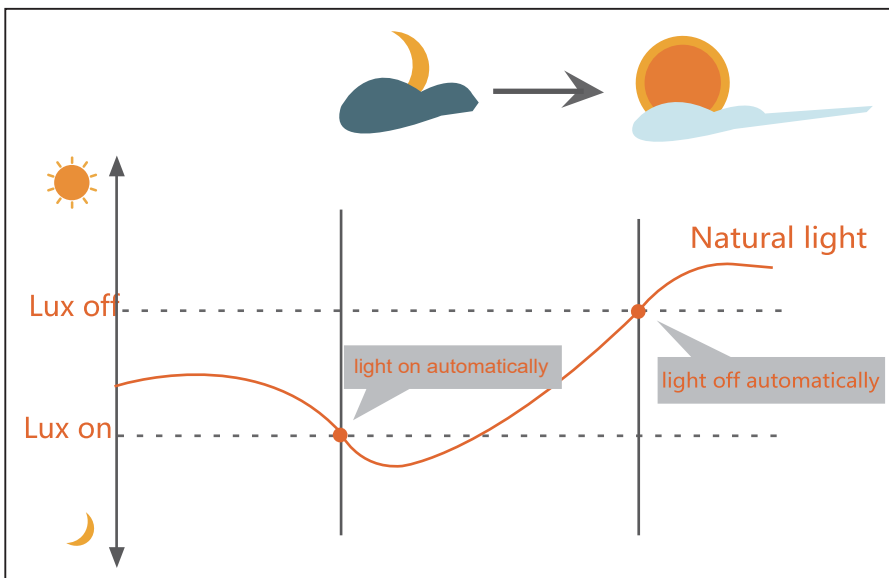

Preconditions to use the Lux-off function:

1. Standby period is +∞;
2. Standby dimming level is on 10%, or 50%;
3. Daylight threshold is on 30Lux-50Lux, 80Lux or 100Lux.

● Application——Lux on/off

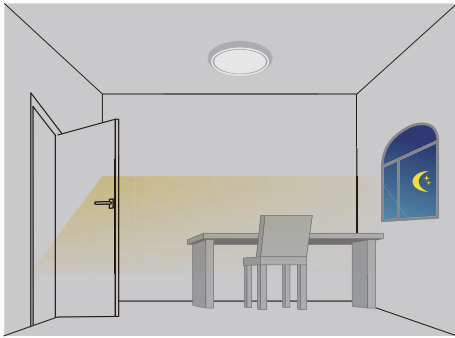

Light automatically on when ambient brightness is lower than preset lux level.



With insufficient ambient brightness, light dims to 100% when motion detected.

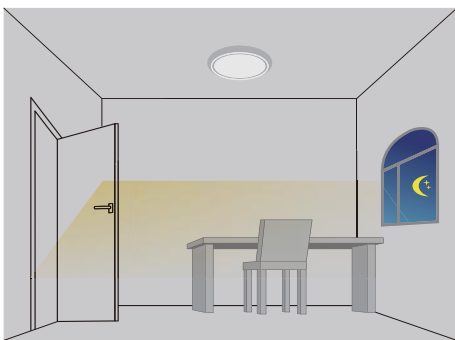

Light dims to standby level if no motion detected after holdtime.

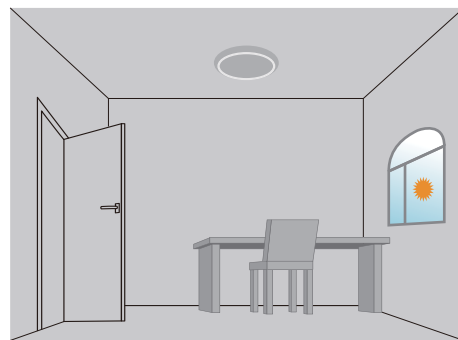

Light off when ambient lux level is higher than preset lux amount.

● Application——Dimmable control/Corridor function

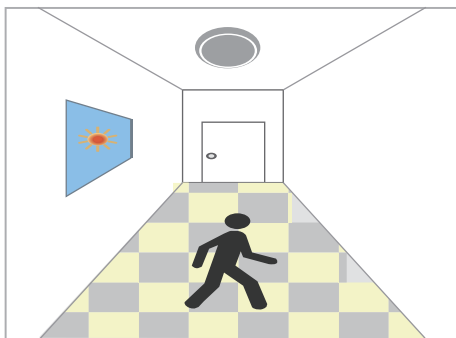

With sufficient daylight, even when motion detected, light remains OFF.



With insufficient daylight, when motion detected, light ON.



After the stand-by period, light OFF. After last detection, the light will be dimmed down to the stand-by dimming level (10%, 20%, 30% or 50%) after holdtime.

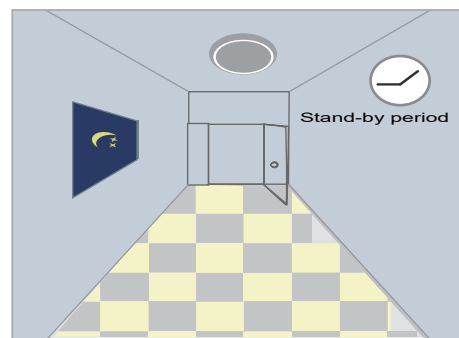

Light dims to standby level if no motion detected after holdtime.

Emergency LED Driver

Features

- Easy wiring: directly connect to AC input of LED lamps
- Ideal for many kinds of indoor LED fixtures with 0/1-10V dimming wires
(Can work with up to 25W LED lamps without dimming function)
- UL Listed for US and Canada.
- Listed for factory or field installation-UL924&CSA C22.2 NO.141
- Constant Power output
- Input voltage:100-347Vac,50/60Hz
- Battery protections:over temperature protection,over charge protection
Over discharge protection,shortcircuit protection.
- Self testing monthly/yearly
- Can work with sensors
- 5 years warranty
- RoHS compliant
- Meet CEC Title 20 standards(california energy commission)



Specifications

MODEL NO.	BLD-HM15D-480800	BLD-HM20D-480800	BLD-HM25D-480800
Input Voltage	100-347Vac, 50/60Hz	100-347Vac, 50/60Hz	100-347Vac, 50/60Hz
Input Current	<100mA	<100mA	<100mA
Input Power	8W max	8W max	8W max
Output Voltage	≤175V DC	≤175V DC	≤175V DC
Output Power	15W	20W	25W
Application	① 3.5-100W(0/1-10V Dimmable Fixture) ② ≤15W LED Lamps without dimming function	① 3.5-100W(0/1-10V Dimmable Fixture) ② ≤20W LED Lamps without dimming function	① 3.5-100W(0/1-10V Dimmable Fixture) ② ≤25W LED Lamps without dimming function
Ambient Temperature	0°C to +50°C(30°F to 122°F)	0°C to +50°C(30°F to 122°F)	0°C to +50°C(30°F to 122°F)

Wiring Diagram

0/1-10V Dimmable LED Driver + Dimmer Switch

Emergency Driver Dim+(Yellow) , Driver Dim-(Green) Have to connect with LED driver DIM+ and DIM-

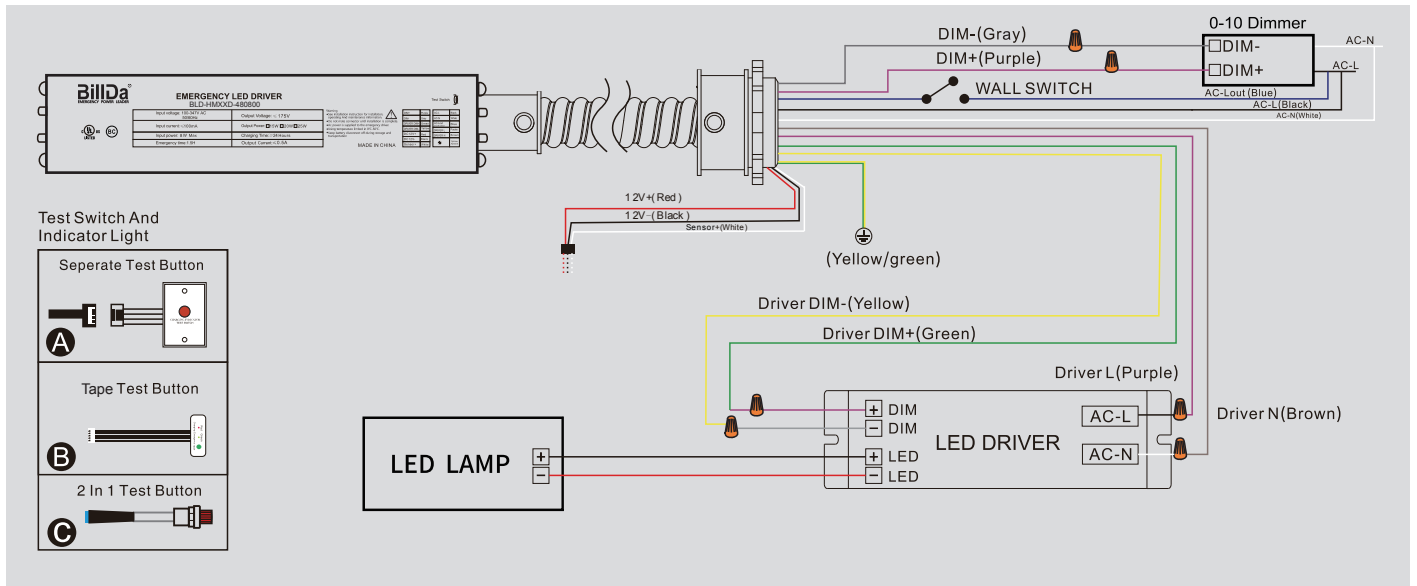

Dimensions

Case: 12.91" X 1.97" X 0.94" (mounting center 8.62")

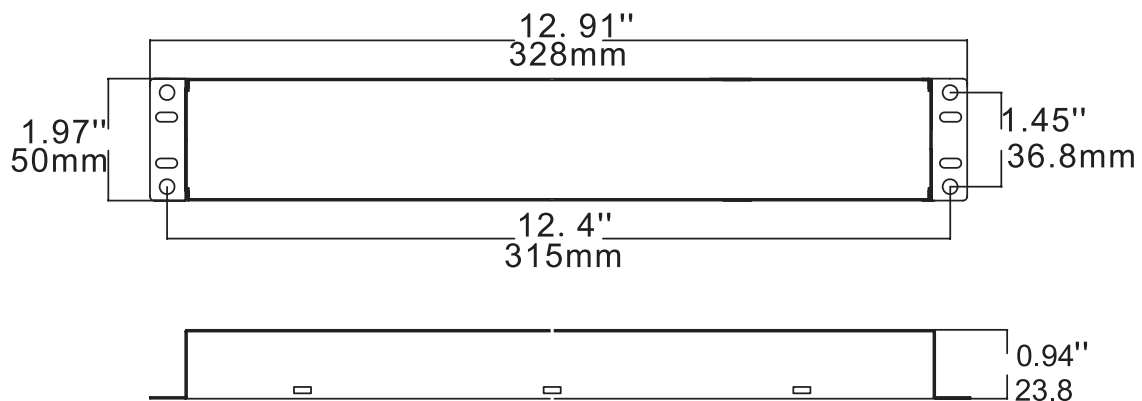

Emergency LED Driver

The integrated self-diagnostic circuitry will automatically conduct monthly 30-second and annual 90-minute tests to verify proper emergency capability per Life Safety Code requirements.

Press the test button to cut the power to the AC driver and switch the system to emergency mode. Release the test button to return to normal mode. Switch off the circuit breaker to simulate a full power outage.

NFPA 101, Life Safety Code outlines the following schedule:

Monthly - Insure that the test button light is illuminated. Conduct a 30 second discharge test by depressing the test button. The LED load should operate at reduced output.

Annually - Insure that the test button is illuminated. Conduct a full 90 minute discharge test. The unit should operate as intended for the duration of the test.

“Written records of the testing shall be kept by the owner for inspection by the authority having jurisdiction.”

- Risk of fire or electric shock. Luminaire wiring and electrical parts may be damaged when drilling for installation of LED Emergency Backup. Check for enclosed wiring and components.
- Risk of fire or electric shock. This LED Emergency Backup installation requires knowledge of luminaire. electrical systems. If not qualified, do not attempt installation. Contact a qualified electrician.
- Before installing, make certain the AC power to the fixture is off.
- The electrical rating of this product is 100-347Vac. Installer must confirm that there is 100-347Vac to the fixture before installation.
- To prevent electrical shock only mate unit connector after installation is complete and before the AC power to the fixture is back on.
- This LED Emergency Backup unit requires an un-switched AC power source of 100-347Vac, 50/60Hz. The AC driver must be on the same branch circuit as the LED Emergency Backup unit.
- Do not let power supply cords touch hot surfaces.
- Do not mount near gas or electric heaters.
- Do not use outdoors.
- Do not connect battery pack connector until all other wiring is complete and AC power is on.
- The emergency LED driver is for use with grounded, UL listed LED luminaires, shall be enclosed by the LED luminaire and bonded to the grounding of LED luminaire.
- Verify that all replacement lamp types marked on the installed luminaire are also identified as suitable for use with this emergency battery pack.
- The battery pack is fixed by the screw and the indicator lamp is attached to the shell of the luminaire by 3M tape.
- Equipment should be mounted in locations and at heights where it is not be subjected to tampering by unauthorized personnel.
- The use of accessory equipment not recommended by the manufacturer and may cause an unsafe condition.
- Do not use this equipment for other than its intended use.
- Use with grounded, UL Listed, dry or damp location rated fixtures.

Packing /weight

Part NO.	Outer Carton Size (LxWxH)	Qty/Carton (pcs)	Net weight (kg)(lbs)	Gross weight (kg)(lbs)	20GP (QTY)	40HQ (QTY)
2FTLHBA-80WLH 2FTLHBA-110WLH	24.41"*5.39"*13.39" (620*137*340mm)	2	7.6Kg/16.72lbs	8.2Kg/18.04lbs	1874	4436
2FTLHBB-165WLH 2FTLHBB-220WLH	24.41"*5.39"*17.91" (620*137*455mm)	2	9.8Kg/21.56lbs	10.55Kg/23.21lbs	1394	3302
4FTLHBA-165WLH 4FTLHBA-225WLH	46.38"*5.39"*13.39" (1178*137*340mm)	2	14.0Kg/30.8lbs	15.1Kg/32.22lbs	982	2326
4FTLHBB-325WLH	46.38"*5.39"*17.91" (1178*137*455mm)	2	21.0Kg/46.2lbs	22.5Kg/49.5lbs	740	1752
2FTLHBA-110WHH	24.41"*5.39"*13.39" (620*137*340mm)	2	7.6Kg/16.72lbs	8.2Kg/18.04lbs	1874	4436
2FTLHBB-165WHH 2FTLHBB-220WHH	24.41"*5.39"*17.91" (620*137*455mm)	2	9.8Kg/21.56lbs	10.55Kg/23.21lbs	1394	3302
4FTLHBA-225WHH	46.38"*5.39"*13.39" (1178*137*340mm)	2	14.0Kg/30.8lbs	15.1Kg/32.22lbs	982	2326
4FTLHBB-325WHH	46.38"*5.39"*17.91" (1178*137*455mm)	2	21.0Kg/46.2lbs	22.5Kg/49.5lbs	740	1752

Packing

